

Installation Guide Halo Illuminated Mirror

by

 Clearlight Designs®



Installation Instructions

Failure to follow installation instructions could result in serious injury, or damage to property.

Failure to follow installation instructions will void warranty.

Please read these instructions carefully before installation to make sure you have all you need, and to understand what you will be doing during all phases of the handling, installation, removal, operation and maintenance of this product. Failure to comply with these precautions violates safety standards of design, manufacture and intended use of the product.

Clearlight Designs assumes no liability for customer's failure to comply with these requirements.

Installation must only be carried out by a licensed electrician or builder according to local authority regulations.

All electrical works must only be undertaken after disconnection of power by removing fuses or turning off circuit breaker, to ensure all pole isolation of the electrical supply.

IMPORTANT!

Installation must only be carried out by a licensed electrician or builder according to local authority regulations.

**Do not remove protective film or plastic corners until your mirror is installed
Move mirrors SLOWLY. Plan what you are doing.**

Handling Tips

- Always place the mirror on a soft surface e.g. carpet or folded towels. The edge of the mirror will almost certainly chip if placed on a stone or tiles or hard surface.
- If the mirror has to be removed from the wall re-fit the protective corners before moving. (Dont learn this the hard way)
- Do not touch the frosted glass strips on the back of the mirror. You may end up with the extra task of cleaning off your fingerprints.
- Mirrors are heavy and fragile. Always lift with two people to share the load. Move slowly and carefully, plan and discuss what you are going to do.

Before fitting the mounting structure to the wall or wiring for power connection:

You will need to know the location of:

- the wall studs
- water pipes
- electrical cables

Consult your plans and have a licensed electrician install electrical requirements for your mirror in accordance with this installation guide.

Electrical installation

A light switch to operate the mirror should be installed, on the wall or other convenient location, by a licensed electrician. If a demister is fitted to the mirror you will need two cables through the wall. The demister and LEDs can be operated by the same switch or different switches.

The switch/es connect to a power outlet for the driver/s. To ensure easy access the driver/s can be located in the vanity cupboard under the mirror, or in the ceiling.

It is not recommended to locate the driver/s in the wall cavity behind the mirror as the mirror would have to be removed to change out a driver if necessary.

From the driver a low voltage cable will run inside the wall to protrude at the approximate centre of the mirror mounting structure, ready for connection to the LEDs (and de-mister if applicable).

STEP 1 - Fitting the mounting structure to the wall:

The mounting structure is to be installed using a minimum of 5 button head screws of 8 gauge X 40mm length, combined with the appropriate wall plugs or expanding wall anchors depending on the type of wall and wall cladding.

If the mounting structure lines up with a wall stud even better, just drill another hole/s in the White MDF and screw through into the wall stud.

Do not drill through the split battens as this will result in bending them out of alignment when screwed to the wall.

Large mirrors (around 2 square metres) will have additional holes in the mounting structure for extra load bearing screws.

As a guide, the mirrors weigh approximately 20kg to 25kg per square metre.

Start by plotting the planned position of the mirror on the wall:

- Mark the top centre and top corners of where the mirror will be on the wall.
- Mark out the position of the hole for the first mounting screw (#1) - 120mm down from the top centre point.
- Drill the first hole in the wall at that position
- Fit wall plug or expanding wall anchor. Then screw the mounting structure to the wall through screw hole #1.
- Adjust to level by pivoting on the screw.
- When level, using the mounting structure as a template, mark out or drill pilot holes into the wall through the holes in the mounting structure.
- Now unscrew the mounting structure and place it aside so you can complete the drilling of the other holes in the wall. Then set up the wall plugs or wall anchors as before and screw the mounting structure to the wall with all screws.
- Check there is no foreign material caught in the split battens.

STEP 2 - Connecting the mirror lights to power

You need at least two people for this next procedure.

- If there is no vanity cupboard in front of the mounting structure use a table or similar. Make sure you have folded towels or similar padding in place to rest the mirror on. Lift the mirror into a vertical position in front of the mounting structure allowing enough room at one side to reach in and join the cables.
- Have someone hold the mirror vertically in place while you take the 12volt cable (protruding from the wall) from the LED driver and connect it to the cable, (from the LEDs on the mirror), using insulated cable joiners.
- The same procedure applies to 12volt cable for demister if demister is fitted to mirror.
- Make sure the wires will not interfere with the split battens when the mirror is lifted into position. Excess cables can be taped out of the way on the mounting structure or preferably inserted into the wall cavity.

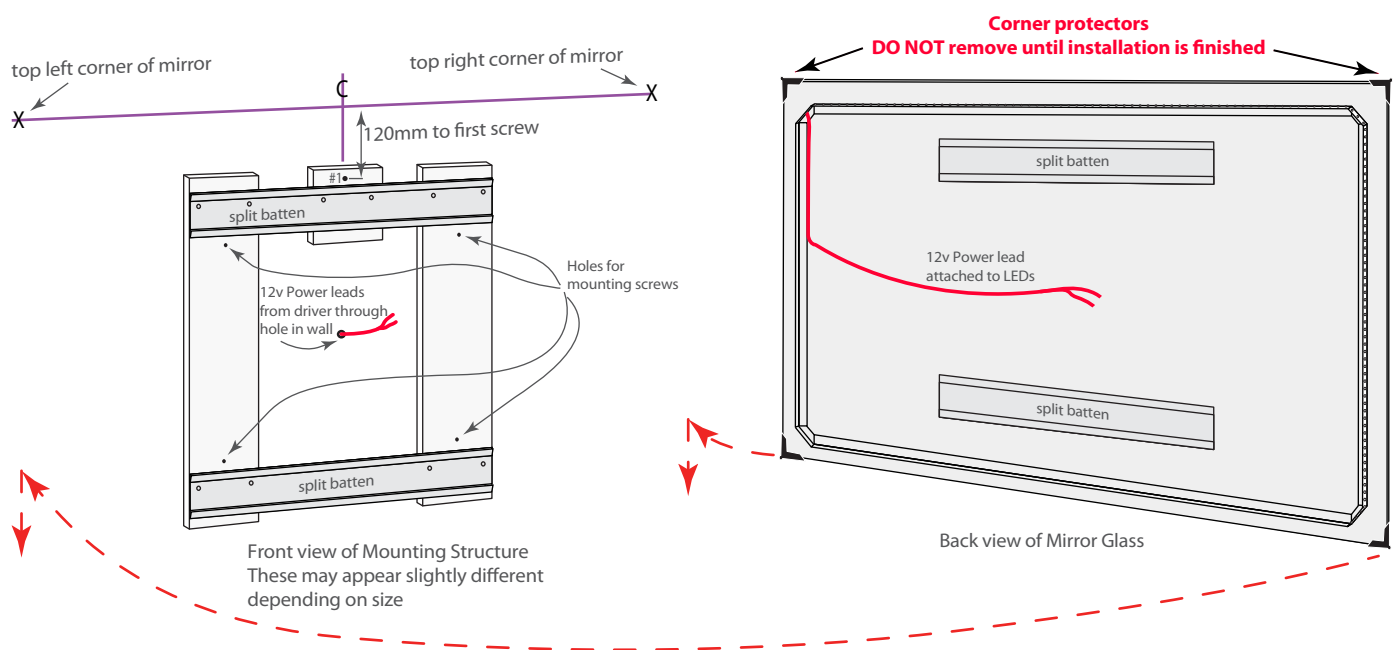

STEP 3 - Hanging the mirror on the mounting structure

- NOTE : First note the position on the wall where the corner of the mirror needs to be i.e. When the mirror is level and placed 20mm to 25mm above the corner marks on the wall the split battens on the mirror will be high enough to engage the split battens on the mounting structure. Do not lift it higher than this.

With two people to lift the mirror, Lift into this position, the mirror can be pressed flat on the wall and allowed to slide down into position to engage the split battens.

NOTE It is possible to engage only the top or bottom batten, so at this point do not release the mirror until you are sure both split battens are engaged and the mirror is sitting flat against the wall. If you need to adjust the mirror sideways just lift slightly so the split battens release their grip and the mirror will be easier to slide.

STEP 4 - Removing the protective plastic

When the mirror is securely in place. Remove corner protectors and carefully peel the protective plastic coating from the front of the mirror glass, starting at the top and slowly peel down.

Care and Cleaning

On the edge of every the mirror there is a thin line of silver that is exposed to the air. Silver will tarnish eventually and the tarnish may spread under the paint. The mirrors we use employ the latest and best paint technology to prevent this. In order to protect your mirror even more we apply an edge sealer. Cleaning the edge of the mirror with commercial cleaners is unnecessary and may eventually damage that edge seal. To clean the mirror edge all you need is a quick wipe down with a soft cloth dampened with distilled water.

DO NOT USE CLEANERS ON THE EDGE OR BACK OF THE MIRROR. Even air born chemicals e.g. toilet flush chemicals, may tarnish your mirror,

When cleaning a mirror simply wipe the glass surface with a few drops of methylated spirits or Isopropyl Alcohol on a clean slightly damp cotton cloth. We have found the Isopropyl Alcohol is the best for cleaning mirrors.

Do not use cleaners containing Ammonia, or bleach, this will void warranty
Some paper towels may leave a smear.

Internal side-view of how the Split battens install works...

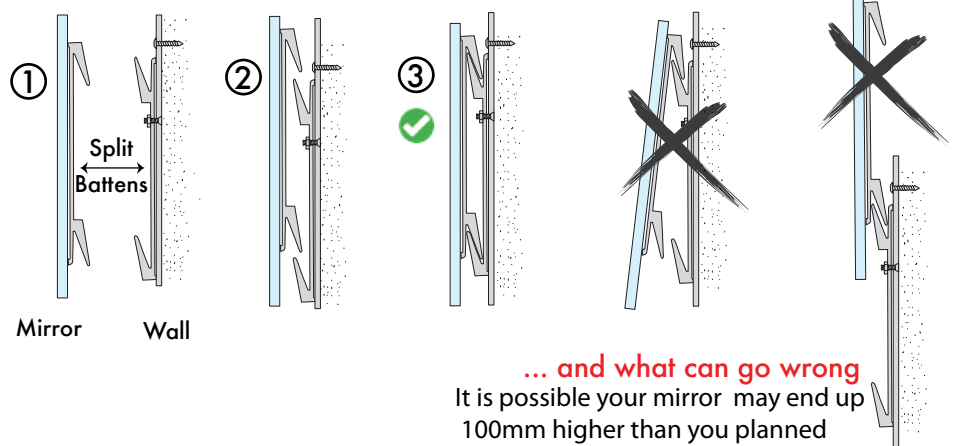
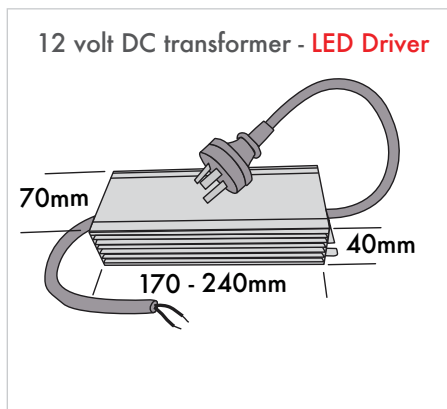

Trouble shooting

If the lights in the mirror malfunction it is most probably the driver.

The driver in question can be swapped out with another driver to resolve the issue or you can contact Clearlight Designs by phone or email.

If there is any other problem with the mirror, or with the LEDs that can not be resolved by swapping out the driver/s contact Clearlight Designs by email - info@clearlightdesigns.com.au or mobile - 0417 621 127, or through the website www.clearlightdesigns.com.au

Uninstalling the mirror is simply a reversal of the installation procedure outlined earlier.